

Construction No. 353

Uplift - Class 90

Fire Not Investigated

ALTERNATE CONSTRUCTION

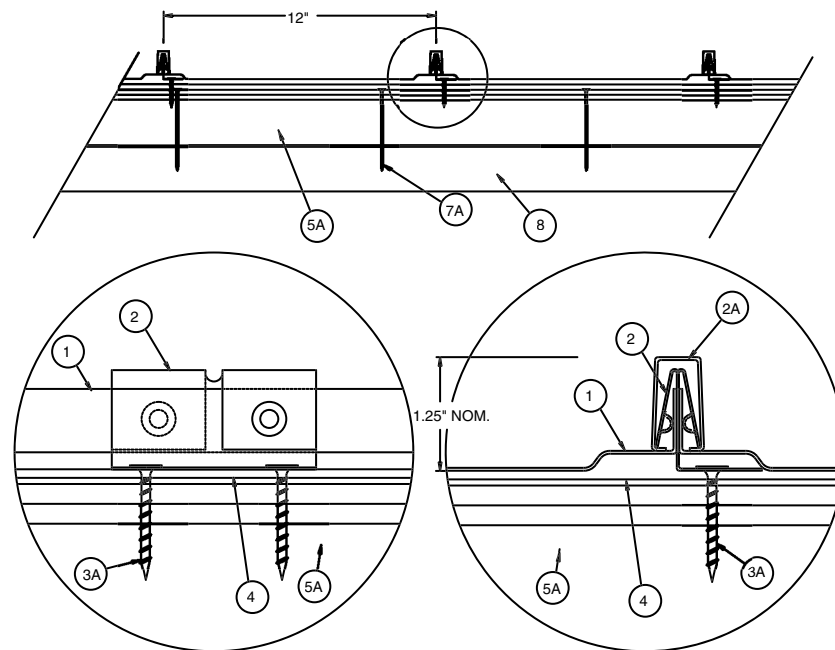

1. **Metal Roof Deck Panels*** - No. 24 MSG min coated steel panels, 12 in. wide, 1-3/8 in. high at side ribs. Panels continuous over three or more clips with no endlaps. A bead of sealant may be used at panel side joints.
Petersen Aluminum Corp. - "Redi-Roof Batten"
- 1A. **Panel Cap** - No. 24 MSG min coated steel. 1 in. high, 1 in. wide "U" shaped with 1/8 in hems on each leg. Designed to snap over panel clips (Item 2).
Petersen Aluminum Corp. - "Redi-Roof Cap"
2. **Roof Deck Fasteners* (Panel Clips)** - One piece assembly, 2-1/4 in. wide, 1-1/2 in. high. Min thickness No. 24 MSG coated steel clips spaced 18 in. OC fastened to plywood deck.
Petersen Aluminum Corp. - "Redi-Roof Clip"
- 3A. **Fasteners (Screws)** - Fasteners used to attach panel Clip (Item 2) to Nailable Insulation (Item 5A) to be 8-8 by 1-1/4 in. long bugle-head coated steel wood screws with a No. 2 Phillips drive. Minimum two fasteners per clip to be used.
4. **Underlayment** - Underlayment used over plywood deck to be Type 30 organic felt. Sides overlapped min 2 in., end laps per manufacturer's instructions. Felt nailed to plywood deck with 1 in. long galv steel roofing nails, located per manufacturer's instructions. Nail spacing to be max 12 in. OC at the side lap and max 24 in. OC in interior rows.
- 5A. **Nailable Insulation** - Consisting of 1 in. min to 3-1/2 in. maximum nominal thickness Classified Polyisocyanurate foamed plastic with a factory laminated 7/16 in. thick APA rated O.S.B. density of foamed plastic to be 2 pcf.
- 6A. **Supports (Purlins)** - Not Shown - Purlins used for liner panel support to be cold formed steel sections. As alternatives, structural steel components (hot rolled beams, channels, open web joists etc.) may be used. Min gauge and yield to depend on design considerations for uplift loading. Max spacing to depend on design considerations for uplift loading.
- 7A. **Fasteners(Screws)** - Fasteners used to attach nailable insulation to steel deck (Item 8) to be No. 3 Phillips drive, truss head, painted steel screws. Length to depend on overall thickness of deck and to penetrate steel deck 1/2 in. min.
2 in. diameter formed pressure plate fabricated from No. 22 MSG coated steel to be used with each screw. Fasteners located in three rows along the 8 ft. length of the nailable insulation beginning 6 in. from the 4 ft. edges OC. A total of 15 fasteners used for each 4 by 8 ft. board.
8. **Liner Panel (Steel Deck)** - No. 22 MSG min thickness coated steel. Min depth 1-1/2 in. max pitch 6 in. fabricated to various profiles. Min yield strength 33,000 psi. Fastened to supports (Item 6A) with fastener type and spacing per liner panel manufacturer's instructions for uplift loading.
9. **Gypsum Board (Optional)** - Max thickness 5/8 in. supplied in 4 by 8 ft. sheets. Butt joints located over crests of steel deck. Fastened to deck with same fasteners used for nailable insulation.
Refer to General Information, Roof Deck Construction (Roofing Materials and Systems Directory) for items not evaluated.

*Bearing the UL Classification Marking.